

JACKSON II

CE



Manuel d'utilisation / Manual del usuario
Owner's manual / Handbuch

PRESIDENT

Downloaded from www.cbradio.nl

Votre PRESIDENT JACKSON II ASC en un coup d'œil

Un vistazo a vuestro PRESIDENT JACKSON II ASC

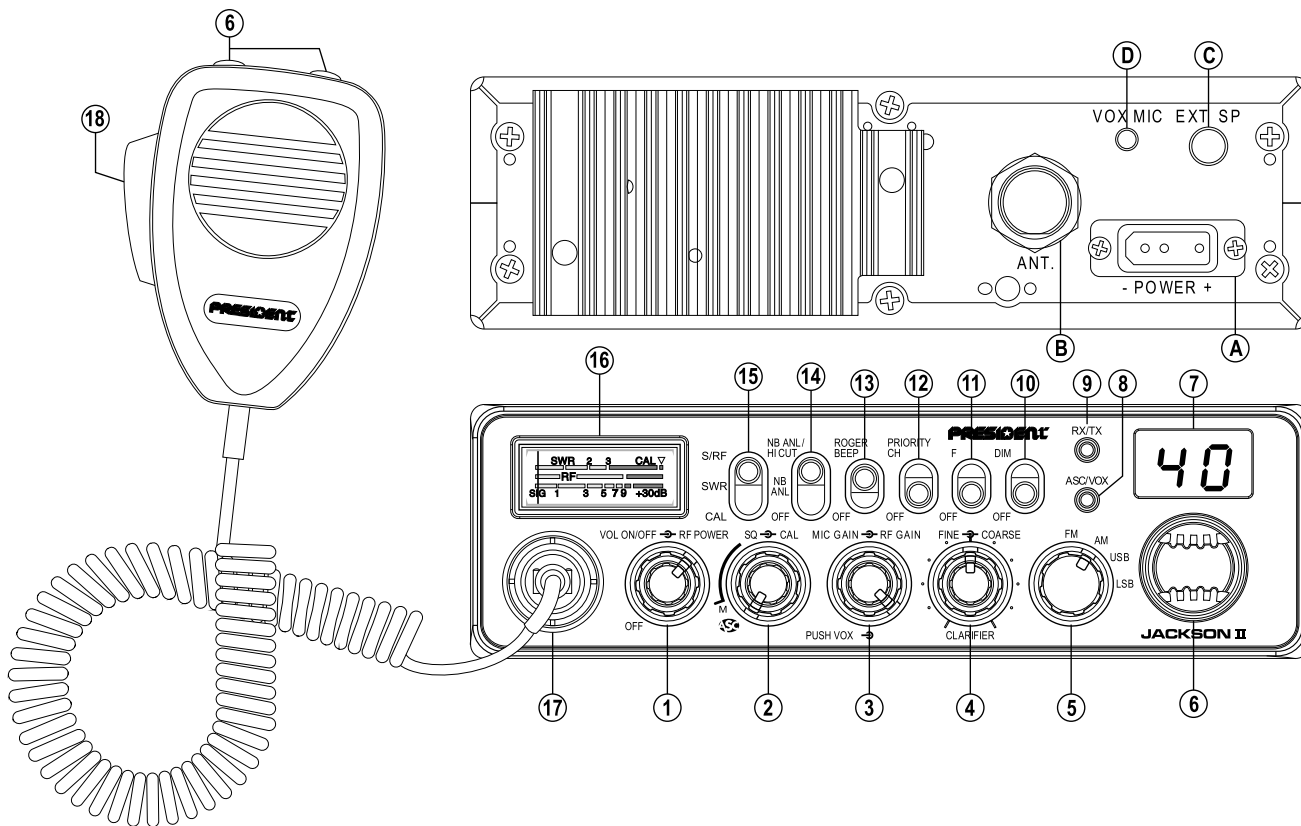

Your PRESIDENT JACKSON II ASC at a glance

Ihr PRESIDENT JACKSON II ASC auf einen Blick

SOMMAIRE

INSTALLATION	5
UTILISATION	7
CARACTÉRISTIQUES TECHNIQUES	10
GUIDE DE DÉPANNAGE	11
COMMENT ÉMETTRE/RECEVOIR UN MESSAGE	11
GLOSSAIRE	11
DÉCLARATION DE CONFORMITÉ	13
GARANTIE	14
TABLEAUX DES FRÉQUENCES	47~ 49
TABLEAU DES NORMES EUROPÉENNES	50

Français

SUMARIO

INSTALACIÓN	17
UTILIZACIÓN	19
CARACTERÍSTICAS TÉCNICAS	22
GUÍA DE PROBLEMAS	23
COMO EMITIR O RECIBIR UN MENSAJE	23
LÉXICO	23
DECLARACIÓN CE DE CONFORMIDAD	25
GARANTÍA	26
TABLAS DE FRECUENCIAS	47~ 49
NORMAS EUROPEAS	50

Español

SUMMARY

INSTALLATION	29
HOW TO USE YOUR CB	31
TECHNICAL CHARACTERISTICS	34
TROUBLE SHOOTING	35
HOW TO TRANSMIT OR RECEIVE A MESSAGE	35
GLOSSARY	35
CERTIFICATE OF CONFORMITY	37
FREQUENCY TABLES	47~ 49
EUROPEAN NORMS	50

English

INHALTSANGABE

INSTALLATION	39
BEDIENUNG	41
TECHNISCHE DATEN	44
BEI PROBLEMEN	45
TIPS FÜR DEN FUNKVERKEHR	45
BEURTEILUNG DER EMPFANGSQUALITÄT	45
KONFORMITÄTSERKLÄRUNG	37
CB-KANÄLE UND IHRE FREQUENZEN	47 ~ 49
EUROPÄISCH NORMEN	50

Deutsch

Welcome to the world of the new generation of CB radios. The new PRESIDENT range gives you access to top performance CB equipment. With the use of up-to-date technology, which guarantees unprecedented quality, your PRESIDENT JACKSON II ASC is a new step in personal communication and is the surest choice for the most demanding of professional CB radio users. To ensure that you make the most of all its capacities, we advise you to read carefully this manual before installing and using your PRESIDENT JACKSON II ASC.

A) INSTALLATION

1) WHERE AND HOW TO MOUNT YOUR MOBILE CB RADIO

- You should choose the most appropriate setting from a simple and practical point of view.
- Your CB radio should not interfere with the driver or the passengers.

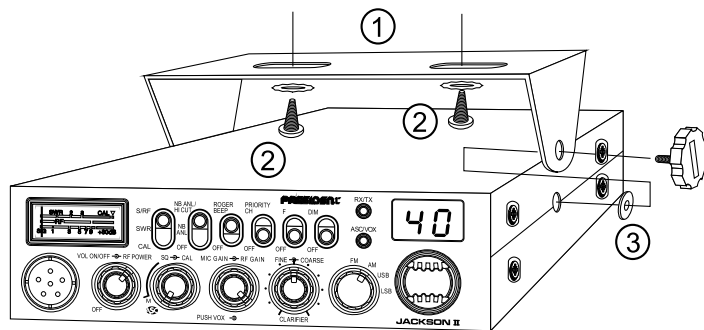

MOUNTING DIAGRAM

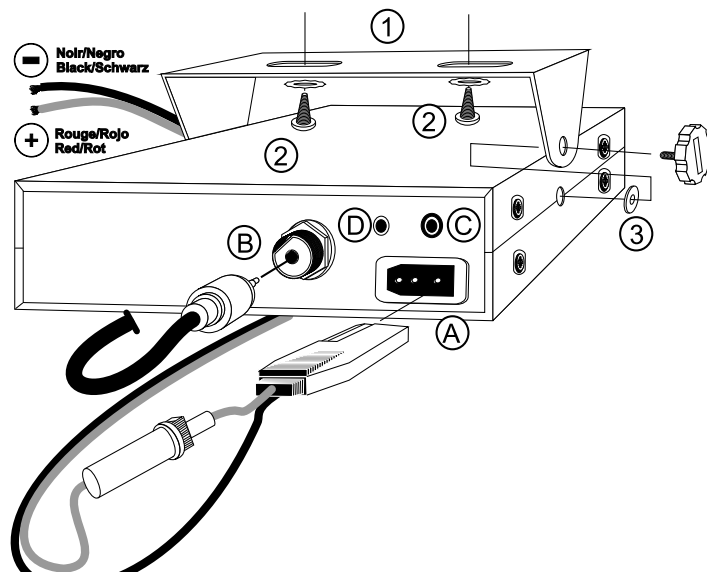

- Remember to provide for the passing and protection of different wires (e.g. power, antenna, accessory cabling) so that they do not in any way interfere with the driving of the vehicle.
 - To install your equipment, use the cradle (1) and the self-tapping screws (2) provided (drilling diameter 3.2 mm). Take care not to damage the vehicle's electrical system while drilling the dash board.
 - Do not forget to insert the rubber joints (3) between the CB and its support as these have a shock-absorbing effect which permits gentle orientation and tightening of the set.
 - Choose where to place the microphone support and remember that the microphone cord must stretch to the driver without interfering with the controls of the vehicle.
- **N.B. :** As the transceiver has a frontal microphone socket, it can be set into the dash board. In this case, you will need to add an external loud speaker to improve the sound quality of communications (connector EXT.SP situated on the back panel: C). Ask your dealer for advice on mounting your CB radio.

2) ANTENNA INSTALLATION

a) Choosing your antenna:

- For CB radios, the longer the antenna, the better its results. Your dealer will be able to help you with your choice of antenna.

b) Mobile antenna:

- Must be fixed to the vehicle where there is a maximum of metallic surface (ground plane), away from windscreen mountings.
- If you already have a radio-telephone antenna installed, the CB antenna should be higher than this.
- There are two types of antenna: pre-regulated which should be used on a good ground plane (e.g. car roof or lid of the boot), and adjustable which offer a much larger range and can be used on a smaller ground plane (see p. 31 § 5, Adjustment of SWR).
- For an antenna which must be fixed by drilling, you will need a good contact between the antenna and the ground plane. To obtain this, you should lightly scratch the surface where the screw and tightening star are to be placed.
- Be careful not to pinch or flatten the coaxial cable (as this runs the risk of break down and/or short circuiting).
- Connect the antenna (B).

c) Fixed antenna:

- A fixed antenna should be installed in a clear space as possible. If it is fixed to a mast, it will perhaps be necessary to stay it, according to the laws in force (you should seek professional advice). All PRESIDENT antennas and accessories are designed to give maximum efficiency to each CB radio within the range.

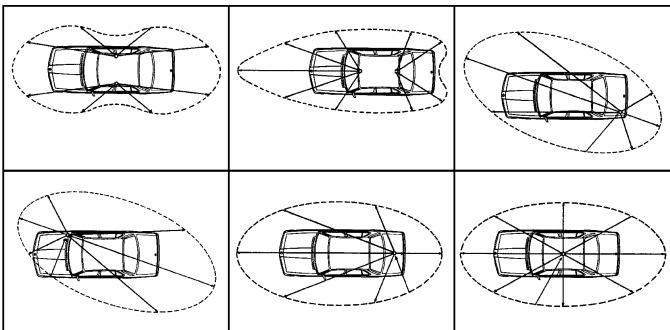

OUTPUT RADIUS PATTERNS

3) POWER CONNECTION

Your PRESIDENT JACKSON II ASC is protected against an inversion of polarities. However, before switching it on, you are advised to check all the connections. Your equipment must be supplied with a continued current of 12 volts (A). Today, most cars and lorries are negative earth. You can check this by making sure that the negative terminal of the battery is connected either to the engine block or to the chassis. If this is not the case, you should consult your dealer.

WARNING: Lorries generally have two batteries and an electrical installation of 24 volts, in which case it will be necessary to insert a 24/12 volt converter (type CV 24/12 PRESIDENT) into the electrical circuit. The following connection steps should be carried out with the power cable disconnected from the set.

- Check that the battery is of 12 volts.
- Locate the positive and negative terminals of the battery (+ is red and - is black). Should it be necessary to lengthen the power cable, you should use the same or a superior type of cable.
- It is necessary to connect your CB to a permanent (+) and (-). We advise you to connect the power cable directly to the battery (as the connection of the CB cable to the wiring of the car-radio or other parts of the electrical circuit may, in somecases, increase the likelihood of interference).
- Connect the red wire (+) to the positive terminal of the battery and the black (-) wire to the negative terminal of the battery.
- Connect the power cable to your CB radio.

WARNING: Never replace the original fuse (6 A) by one of a different value.

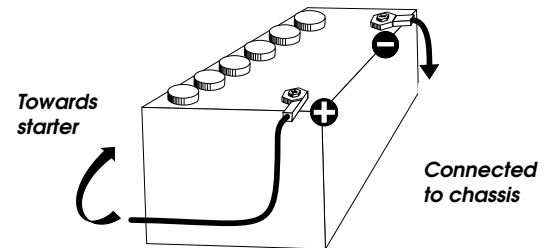

4) BASIC OPERATIONS TO BE CARRIED OUT BEFORE USING YOUR SET FOR THE FIRST TIME (without transmitting and without using the «push-to-talk» switch on the microphone)

- a) Connect the microphone
- b) Check the antenna connections
- c) Turn the set on by turning the volume knob (1) clockwise.
- d) Turn the squelch knob (2) to minimum (M position).
- e) Adjust the volume to a comfortable level.
- f) Go to Channel 20 using either the «UP» «DN» key on the microphone or the rotary knob.

5) ADJUSTMENT OF SWR (Standing wave ratio)

WARNING: This must be carried out when you use your CB radio for the first time (and whenever you re-position your antenna). The adjustment must be carried out in an obstacle-free area.

* **Adjustment with a built-in SWR meter or external SWR meter (e.g. TOS-1 or TOS-2 President)**

- a) To connect the SWR meter :
 - Connect the SWR meter between the CB radio and the antenna as close as possible to the CB (use a maximum of 40 cm cable, type President CA 2C).
- b) To adjust the SWR meter:
 - Set the CB to channel 20 in FM.
 - Put the switch on the SWR meter to position CAL or FWD.
 - Press the «push-to-talk» switch on the microphone to transmit.
 - Bring the index needle to ▼ by using the calibration key.
 - Change the switch to position SWR (reading of the SWR level). The reading on the Meter should be as near as possible to 1. If this is not the case, re-adjust your antenna to obtain a reading as close as possible to 1. (An SWR reading between 1 and 1.8 is acceptable).
 - It will be necessary to re-calibrate the SWR meter after each adjustment of the antenna.

WARNING: In order to avoid any losses and attenuations in cables used for connection between the radio and its accessories, PRESIDENT recommends to use a cable with a length inferior to 3m.

Your CB is now ready for use.

B) HOW TO USE YOUR CB

1) ON/OFF - VOLUME ~ RF POWER

ON/OFF - VOLUME

- a) To turn the set on, turn the knob (1) clockwise.
- b) To increase the sound level, turn the same knob further clockwise.

RF POWER

Adjustment of the output power in AM and FM mode only. Allows reducing the power in case of a nearby communication with a person who has no **RF GAIN**. The normal position of this function is set to maximum, fully clockwise.

2) ASC (Automatic Squelch Control) SQUELCH ~ CAL

SQUELCH

Suppresses undesirable background noises when there is no communication. Squelch does not affect neither sound nor transmission power, but allows a considerable improvement in listening comfort.

a) ASC: Automatic Squelch Control

Worldwide patent, a PRESIDENT exclusivity.

Turn the squelch knob (2) anti-clockwise into **ASC** position. The «**ASC/VOX**» led lights up into green.

Note: If the **VOX** function is also active, the led lights up into orange.

No repetitive manual adjustment and a permanent improvement in listening comfort when ASC is active. This function can be disconnected by turning the switch clockwise. In this case the manual squelch control becomes active again. The «**ASC/VOX**» led turns off.

b) MANUAL SQUELCH

Turn the squelch knob clockwise to the exact point where all background noise disappears. This adjustment should be done with precision as, if set to maximum (fully clockwise) only the strongest signals will be received.

CAL

Allows the calibration of the SWR meter (see § 5 ADJUSTMENT OF SWR).

3) MIC GAIN ~ RF GAIN ~ VOX

MIC GAIN

Adjustment of the sensitivity level of the microphone.
The normal position of this function is set to maximum clockwise.

RF GAIN

This knob is for adjusting sensitivity during reception. For long distance communications **RF GAIN** should be set to maximum. RF GAIN can be reduced to avoid distortion, when your correspondent is close by and when he does not have RF POWER.

The normal setting of this function is on maximum (fully clockwise).

VOX

The **VOX** function allows transmitting by speaking into the original microphone (or in the optional vox microphone) without pressing the PTT switch. In case of the use of an optional vox mike connected to the rear panel of the radio (VOX MIC jack), the original microphone doesn't work.

a) VOX Mode

Press shortly the «**VOX**» key in order to activate the **VOX** function. The red «**ASC/VOX**» led lights up. A new pressure on the «**VOX**» key switches the function off. The «**ASC/VOX**» led turns off.

Note: If the **ASC** function is also active, the led turns up into orange.

b) VOX adjustment

Press during 1 second the «**VOX**» key in order to activate the function. **Vox adjustment.** Three adjustments are possible: *Sensitivity, Anti-Vox level/Vox delay time.* The preset adjustment is the Sensitivity adjustment. Press shortly the «**VOX**» key in order to go to the following adjustment. The display shows the type of adjustment by its first digit and its level by the second digit.

- **Sensitivity** «L5»: allows the adjustment of the microphone (original one or optional vox) for an optimum transmission quality. Adjustable level from 1 (high level) to 9 (low level) by rotating the channel knob or with the **UP/DN** keys of the original microphone. *L* corresponds to the Sensitivity (Level).
- **Anti-Vox** «R0»: allows disabling the transmission generated by the surrounding noise. The level is adjustable from 0 (Off) to 9 (low level) by rotating the channel knob or with the **UP/DN** keys of the original microphone. *R* corresponds to **Anti-Vox**.
- **Delay Time** «t5»: allows avoiding the sudden cut of the transmission by adding a delay at the end of speaking. The level is adjustable from 1 (short delay) to 9 (long delay) by rotating the channel selector or with the **UP/DN** keys of the

original microphone. *t* corresponds to delay time.

Once the adjustments are done, press during 1 second the «**VOX**» key in order to quit the **Vox Adjustment Mode**.

4) CLARIFIER

FINE: This function allows a frequency deviation during LSB/USB reception in order to improve the clearness of your correspondent's voice.

COARSE: This function allows a frequency deviation in reception.
The normal setting of this function is on the central position.

5) FM / AM / USB / LSB MODE SELECTOR

This switch allows selecting the modulation mode AM, FM, LSB or USB; Your modulation mode has to correspond to the one of your correspondent.

Frequency Modulation / FM: for nearby communications on a flat open field.

Amplitude Modulation / AM: communication on a field with relief and obstacles at middle distance (the most used).

Upper and Lower Side Band / USB-LSB: used for long distance communications (according to the propagation conditions).

6) CHANNEL SELECTOR: knob and UP/DN keys of the microphone

These switches allow increasing or decreasing a channel number. A «Beep» sounds each time the channel changes if the **Beep** function is activated (see *Beep Function hereunder*).

BEEP FUNCTION

Keys, changing the channel etc.

For activating the Beep: switch on the radio by pressing the **UP** key of the microphone

For disabling the Beep: switch on the radio by pressing the **DN** key of the microphone

SCAN FUNCTION

In order to activate the **SCAN** function (research of the channels) in an increasing way, press the **UP** key during 2,5 seconds. The scanning automatically starts 3 seconds after the end of the transmission if no key is activated. The scanning starts again in an increasing way by using the **UP** key of the microphone or in a decreasing way with the **DN** key of the mike.

7) DISPLAY

The digital LED display shows the channel, its configuration and the level of some adjustments.

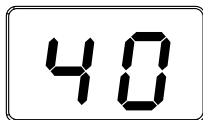

8) ASC/VOX LED

This led is green when the **ASC** function is active and red when the **VOX** function is active. It's orange when both functions are active.

9) RX/TX LED

This led is red in transmission and green when a signal is received.

10) DIM

The **DIMMER** function allows adjusting the brightness of the lighting.

11) F

Selection of the frequency bands (configuration :E; d; EU; EC; U; PL)
The frequency bands have to be chosen according with the country of use. Don't use another configuration. Some countries need a user's licence. See *the configurations / frequency bands table at page 47-49*.

Proceeding: - switch off the transceiver. Put the switch on «F» position and switch on again. The letter corresponds to the blinking configuration.

- In order to change the configuration, use the channel selector on the front panel or the **UP/DN** keys of the microphone.
- When the configuration is selected, put the switch on «OFF». The letter that corresponds to the configuration are continuously displayed. At this point, confirm the selection by switching **off** the transceiver and then switching it **on** again.

See table page 50.

12) PRIORITY CHANNEL

This switch selects channel 9 or 19 according to the configuration.
See table page 50.

13) ROGER BEEP

The **Roger beep** sounds while releasing the microphone key in order to let your correspondent speak. Historically, CB is a mode of «simplex» communication. This means that it is not possible to speak and to listen at the same time (as it

is the case with a telephone). Once someone had finished to talk, he said ("Roger" in order to prevent his correspondent that it was his turn to talk. "Roger" has been replaced by a beep. There comes «**Roger beep**» from.

Note: the «**Roger Beep**» also sounds in the loudspeaker if the function is already active while switching on the transceiver. If the function is on **OFF** while switching on the radio, only the correspondent can hear the «**Roger Beep**».

14) NB.ANL / HI-CUT

3 positions switch: **Off** / **NB.ANL** filter activated / **NB.ANL + HI-CUT** activated.
NB.ANL: Noise Blanker / Automatic Noise Limiter. These filters allow reducing back ground noises and some reception interferences. In FM and USB/LSB mode, only the NB filter is active.
HI-CUT: Cuts out the high frequency interferences and has to be used in accordance with the reception conditions.

15) S/Rf ~ SWR ~ CAL

3 positions switch: changing meter function.

S/Rf

Analogue S/Rf meter which shows the power in transmission and reception.

SWR

Shows the value of the SWR (see *proceedings of the SWR adjustment at page 31*).

CAL

Calibration of the SWR meter (see *proceedings of the SWR meter at page 31*).

16) METER

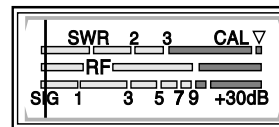

Shows the level of the signal in transmission and reception, the SWR or the calibration of the SWR according to the position of the S/Rf-SWR-CAL (15) switch.

17) 6-PIN MICROPHONE PLUG

This plug is situated on the front panel of the radio making the setting of the equipment into the dashboard easier.

See the cabling diagram at page 49.

18) PTT

Transmission key, press to speak and release to receive a message.

A) POWER SUPPLY (13.2 V)

B) ANTENNA CONNECTOR (SO-239)

C) JACK FOR EXTERNAL LOUDSPEAKER (8 Ω , \emptyset 3,5 mm)

D) JACK FOR OPTIONAL VOX MIKE (\emptyset 2,5 mm)

C) TECHNICAL CHARACTERISTICS:

1) GENERAL:

- Channels : 40
- Modulation modes : AM / FM / USB / LSB
- Frequency ranges : from 26.965 MHz to 27.405 MHz
- Antenna impedance : 50 ohms
- Power supply : 13.2 V
- Dimensions (in mm) : 185 (W) x 264.5 (D) x 56 (H)
- Weight : 1,5 kg
- Accessories supplied : microphone UP/DOWN with hanger, mounting cradle, screws and fused power cord.

2) TRANSMISSION:

- Frequency allowance : +/- 300 Hz
- Carrier power : 1 W AM / 4 W FM / 4 W USB-LSB (PEP)
- Transmission interference : inferior to 4 nW (- 54 dBm)
- Audio response : 300 Hz to 3 KHz in AM/FM/USB/LSB
- Emitted power in the adj. channel : inferior to 20 μ W
- Microphone sensitivity : 3.0 mV
- Drain : 3 A (with modulation)
- Modulated signal distortion : 1.8 %

3) RECEPTION:

- Maxi. sensitivity at 20 dB sinad : 0.7 μ V - 110 dBm (AM)
0.35 μ V - 116 dBm (FM)
0.28 μ V - 118 dBm (USB/LSB)
- Frequency response : 300 Hz to 3 kHz in AM/FM
- Adjacent channel selectivity : 60 dB
- Maximum audio power : 3 W
- Squelch sensitivity : minimum 0.2 μ V - 120 dBm
maximum 1 mV - 47 dBm
- Frequency image rejection rate : 60 dB
- Intermediate frequency rej. rate : 70 dB
- Drain : 400 mA nominal / 1000 mA maximum

D) TROUBLE SHOOTING:

1) YOUR CB RADIO WILL NOT TRANSMIT OR YOUR TRANSMISSION IS OF POOR QUALITY:

- Check that the antenna is correctly connected and that the SWR is properly adjusted.
- Check that the microphone is properly plugged in.
- Check that the RF POWER switch (1) is set on maximum.
- Check that the CLARIFIER, FINE/COARSE (4) switches are set on central position.

2) YOUR CB RADIO WILL NOT RECEIVE OR RECEPTION IS POOR:

- Check that the RFGAIN (3) is set on maximum.
- Check that the squelch level is properly adjusted.
- Check that the programmed configuration is the good one (see table at page 50).
- Check that the volume is set to a comfortable listening level.
- Check that the microphone is properly plugged in.
- Check that the antenna is correctly connected and that the SWR is properly adjusted.
- Check that you are using the same modulation mode as your correspondent.
- Check that the CLARIFIER, FINE/COARSE (4) switches are set on central position.

3) YOUR CB WILL NOT LIGHT UP:

- Check the power supply.
- Check the connection wiring.
- Check the fuse.

E) HOW TO TRANSMIT OR RECEIVE A MESSAGE:

Now that you have read the manual, make sure that your CB Radio is ready for use (i.e. check that your antenna is connected).

Choose your channel (19, 27).

Choose your mode (AM/FM) which must be the same as that of your correspondent.

Press the «push-to-talk» switch and announce your message «Attention stations, transmission testing» which will allow you to check the clearness and the power of your signal. Release the switch and wait for a reply. You should receive a reply like, «Strong and clear».

If you use a calling channel (19, 27) and you have established communication with someone, it is common practice to choose another available channel so as not to block the calling channel.

F) GLOSSARY:

Below you will find some of the most frequently used CB radio expressions. Remember this is meant for fun and that you are by no means obliged to use them. In an emergency, you should be as clear as possible.

INTERNATIONAL PHONETIC ALPHABET:

A Alpha	H Hotel	O Oscar	V Victor
B Bravo	I India	P Papa	W Whiskey
C Charlie	J Juliett	Q Quebec	X X-ray
D Delta	K Kilo	R Romeo	Y Yankee
E Echo	L Lima	S Sierra	Z Zulu
F Foxtrott	M Mike	T Tango	
G Golf	N November	U Uniform	

TECHNICAL VOCABULARY:

AM	: Amplitude Modulation
CB	: Citizen's Band
CH	: Channel
CW	: Continuous Wave
DX	: Long Distance Liaison
DW	: Dual Watch
FM	: Frequency Modulation
GMT	: Greenwich Meantime
HF	: High Frequency
LF	: Low Frequency
LSB	: Lower Side Band
RX	: Receiver
SSB	: Single Side Band
SWR	: Standing Wave Ratio
SWL	: Short Wave Listening
SW	: Short Wave

TX : CB Transceiver
 UHF : Ultra High Frequency
 USB : Upper Side Band
 VHF : Very High Frequency

CB LANGUAGE:

Advertising : Flashing lights of police car
 Back off : Slow down
 Basement : Channel 1
 Base station : A CB set in fixed location
 Bear : Policeman
 Bear bite : Speeding fine
 Bear cage : Police station
 Big slab : Motorway
 Big 10-4 : Absolutely
 Bleeding : Signal from an adjacent channel interfering with the transmission
 Blocking the channel : Pressing the PTT switch without talking
 Blue boys : Police
 Break : Used to ask permission to join a conversation
 Breaker : A CBER wishing to join a channel
 Clean and green : Clear of police
 Cleaner channel : Channel with less interference
 Coming in loud and proud : Good reception
 Doughnut : Tyre
 Down and gone : Turning CB off
 Down one : Go to a lower channel
 Do you copy? : Understand?
 DX : Long distance
 Eighty eights : Love and kisses
 Eye ball : CBers meeting together
 Good buddy : Fellow CBER
 Hammer : Accelerator
 Handle : CBER's nickname
 Harvey wall banger : Dangerous driver
 How am I hitting you? : How are you receiving me?
 Keying the mike : Pressing the PTT switch without talking
 Kojac with a kodak : Police radar
 Land line : Telephone
 Lunch box : CB set
 Man with a gun : Police radar
 Mayday : SOS
 Meat wagon : Ambulance

Midnight shopper : Thief
 Modulation : Conversation
 Negative copy : No reply
 Over your shoulder : Right behind you
 Part your hair : Behave yourself - police ahead
 Pull your hammer back : Slow down
 Rat race : Congested traffic
 Rubberbander : New CBER
 Sail boat fuel : Wind
 Smokey dozing : Parked police car
 Smokey with a camera : Police radar
 Spaghetti bowl : Interchange
 Stinger : Antenna
 Turkey : Dumb CBER
 Up one : Go up one channel
 Wall to wall : All over/everywhere
 What am I putting to you? : Please give me an S-meter reading.

CERTIFICATE OF CONFORMITY

We, *GROUPE PRESIDENT ELECTRONICS*, Route de Sète, BP 100 – 34540 Balaruc – FRANCE,

Declare, on our own responsibility that the CB radio-communication transceiver

Brand : **PRESIDENT**

Model : **JACKSON II**

Manufactured in PRC

is in conformity with the essential requirements of the Directive 1999/5/CE (Article 3) adapted to the national law, as well as with the following European Standards:

EN 300 135-1 V1.1.2 (2000-8) / EN 300 135-2 V1.1.1 (2000-8)
EN 300 433-1 V1.1.3 (2000-12) / EN 300 433-2 V1.1.2 (2000-12)
EN 301 489-1 V1.7.1 (2007-4) / EN 301 489-13 V1.2.1 (2002-8)
EN 60215 (1996)

Balaruc, the **2007-10-01**

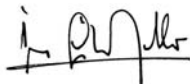

Jean-Gilbert MULLER
General Manager

KONFORMITÄTSERKLÄRUNG

Wir, *GROUPE PRESIDENT ELECTRONICS*, Route de Sète, BP 100 – 34540 Balaruc – FRANCE,

Erklären, auf eigene Verantwortung daß der CB Funk Sender-Empfänger

Marke : **PRESIDENT**

Modell : **JACKSON II**

Hergestellt in PRC

in Konformität ist mit den wesentlichen Anforderungen der R & TTE Richtlinie 1999/5/CE (Artikel 3) auf die nationale Gesetzen umgestellt, wie mit den folgenden europäischen Normen:

EN 300 135-1 V1.1.2 (2000-8) / EN 300 135-2 V1.1.1 (2000-8)
EN 300 433-1 V1.1.3 (2000-12) / EN 300 433-2 V1.1.2 (2000-12)
EN 301 489-1 V1.7.1 (2007-4) / EN 301 489-13 V1.2.1 (2002-8)
EN 60215 (1996)

Balaruc, den **01/10/2007**



Jean-Gilbert MULLER
Geschäftsführer

TABEAU DES FRÉQUENCES pour EU / E / EC / U (CEPT)**TABLA DE FRECUENCIAS para EU / E / EC / U (CEPT)****FREQUENCY TABLE for EU / E / EC / U (CEPT)****CB-KANÄLE UND IHRE FREQUENZEN für EU / E / EC / U (CEPT)**

N° du canal N° Canal Channel Kanal	Fréquences Frecuencia Frequency Frequenzen	N° du canal N° Canal Channel Kanal	Fréquences Frecuencia Frequency Frequenzen
1	26,965 MHz	21	27,215 MHz
2	26,975 MHz	22	27,225 MHz
3	26,985 MHz	23	27,255 MHz
4	27,005 MHz	24	27,235 MHz
5	27,015 MHz	25	27,245 MHz
6	27,025 MHz	26	27,265 MHz
7	27,035 MHz	27	27,275 MHz
8	27,055 MHz	28	27,285 MHz
9	27,065 MHz	29	27,295 MHz
10	27,075 MHz	30	27,305 MHz
11	27,085 MHz	31	27,315 MHz
12	27,105 MHz	32	27,325 MHz
13	27,115 MHz	33	27,335 MHz
14	27,125 MHz	34	27,345 MHz
15	27,135 MHz	35	27,355 MHz
16	27,155 MHz	36	27,365 MHz
17	27,165 MHz	37	27,375 MHz
18	27,175 MHz	38	27,385 MHz
19	27,185 MHz	39	27,395 MHz
20	27,205 MHz	40	27,405 MHz

TABEAU DES FRÉQUENCES pour U (ENG)**TABLA DE FRECUENCIAS para U (ENG)****FREQUENCY TABLE for U (ENG)****CB-KANÄLE UND IHRE FREQUENZEN für U (ENG)**

N° du canal N° Canal Channel Kanal	Fréquences Frecuencia Frequency Frequenzen	N° du canal N° Canal Channel Kanal	Fréquences Frecuencia Frequency Frequenzen
1	27,60125	21	27,80125
2	27,61125	22	27,81125
3	27,62125	23	27,82125
4	27,63125	24	27,83125
5	27,64125	25	27,84125
6	27,65125	26	27,85125
7	27,66125	27	27,86125
8	27,67125	28	27,87125
9	27,68125	29	27,88125
10	27,69125	30	27,89125
11	27,70125	31	27,90125
12	27,71125	32	27,91125
13	27,72125	33	27,92125
14	27,73125	34	27,93125
15	27,74125	35	27,94125
16	27,75125	36	27,95125
17	27,76125	37	27,96125
18	27,77125	38	27,97125
19	27,78125	39	27,98125
20	27,79125	40	27,99125

TABLEAU DES FRÉQUENCES pour d
TABLA DE FRECUENCIAS para d
FREQUENCY TABLE for d
CB-KANÄLE UND IHRE FREQUENZEN für d

N° du canal N° Canal Channel Kanal	Fréquences Frecuencia Frequency Frequenzen	N° du canal N° Canal Channel Kanal	Fréquences Frecuencia Frequency Frequenzen
1	26,965	21	27,215
2	26,975	22	27,225
3	26,985	23	27,255
4	27,005	24	27,235
5	27,015	25	27,245
6	27,025	26	27,265
7	27,035	27	27,275
8	27,055	28	27,285
9	27,065	29	27,295
10	27,075	30	27,305
11	27,085	31	27,315
12	27,105	32	27,325
13	27,115	33	27,335
14	27,125	34	27,345
15	27,135	35	27,355
16	27,155	36	27,365
17	27,165	37	27,375
18	27,175	38	27,385
19	27,185	39	27,395
20	27,205	40	27,405

N° du canal N° Canal Channel Kanal	Fréquences Frecuencia Frequency Frequenzen	N° du canal N° Canal Channel Kanal	Fréquences Frecuencia Frequency Frequenzen
41	26,565	61	26,765
42	26,575	62	26,775
43	26,585	63	26,785
44	26,595	64	26,795
45	26,605	65	26,805
46	26,615	66	26,815
47	26,625	67	26,825
48	26,635	68	26,835
49	26,645	69	26,845
50	26,655	70	26,855
51	26,665	71	26,865
52	26,675	72	26,875
53	26,685	73	26,885
54	26,695	74	26,895
55	26,705	75	26,905
56	26,715	76	26,915
57	26,725	77	26,925
58	26,735	78	26,935
59	26,745	79	26,945
60	26,755	80	26,955

TABLEAU DES FRÉQUENCES pour PL
 TABLA DE FRECUENCIAS para PL
 FREQUENCY TABLE for PL
 CB-KANÄLE UND IHRE FREQUENZEN für PL

N° du canal N° Canal Channel Kanal	Fréquences Frecuencia Frequency Frequenzen	N° du canal N° Canal Channel Kanal	Fréquences Frecuencia Frequency Frequenzen
1	26,960	21	27,210
2	26,970	22	27,220
3	26,980	23	27,250
4	27,000	24	27,230
5	27,010	25	27,240
6	27,020	26	27,260
7	27,030	27	27,270
8	27,050	28	27,280
9	27,060	29	27,290
10	27,070	30	27,300
11	27,080	31	27,310
12	27,100	32	27,320
13	27,110	33	27,330
14	27,120	34	27,340
15	27,130	35	27,350
16	27,150	36	27,360
17	27,160	37	27,370
18	27,170	38	27,380
19	27,180	39	27,390
20	27,200	40	27,400

PRISE MICRO 6 BROCHES
 CONEXIÓN DEL MICRO 6 PINS
 6-PIN MICROPHONE PLUG
 BELEGUNG DER MIKRO-FONBUCHSE (sechspolig)

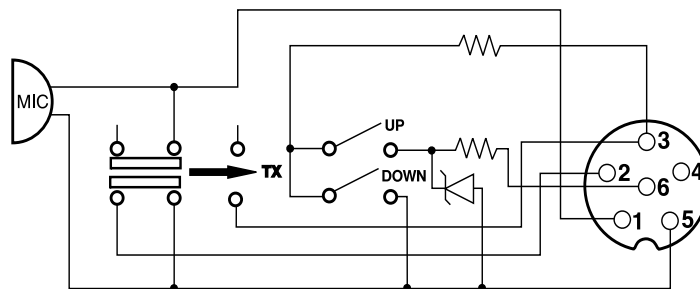

1	Modulation	Modulación	Modulation	Modulation
2	RX	RX	RX	RX
3	TX - UP/DOWN	TX - UP/DOWN	TX - UP/DOWN	TX - UP/DOWN
4	-	-	-	-
5	Masse	Masa	Ground	Masse
6	Alimentation	Alimentación	Power Supply	Stromversorgung

NORMES EUROPÉENNES - NORMAS EUROPEAS - EUROPEAN NORMS - EUROPÄISCH NORMEN

Configuration Code	FM Channel	AM Channel	USB Channel	LSB Channel	Country	Priority CH
E	40 Ch (4W)	40 Ch (4W)	40 Ch (12W)	40 Ch (12W)	ES, IT	19
d	80 Ch (4W)	40 Ch (1W)	40 Ch (4W)	40 Ch (4W)	DE	9
EU	40 Ch (4W)	40 Ch (1W)	40 Ch (4W)	40 Ch (4W)	CH, CY, DK, ES, FI, FR, GR, IE, IS, IT, LT, NL, PT, RO, SE	19
EC	40 Ch (4W)	-	-	-	AT, BE, BG, CZ, EE, HU, LU, LV, MT, NO, SI, SK	9
U	CEPT 40 Ch (4W) + ENG 40 Ch (4W)	-	-	-	GB	9
PL	-5 KHz 40 Ch (4W)	-5 KHz 40 Ch (4W)	-	-	PL	19

Remarque : **Dans la configuration U** : Pour sélectionner la bande de fréquences **ENG**, mettre le commutateur de mode (5) sur la position «**FM**». Pour sélectionner la bande de fréquences **CEPT**, mettre le commutateur de mode (5) sur la position «**AM**» ou «**USB**» ou «**LSB**» (voir tableau page 47).

Note: **In U configuration**: In order to select the frequency band **ENG**, set the mode switch (5) on «**FM**» position. In order to select the **CEPT** frequency band, set the mode switch (5) on position «**AM**» or «**USB**» or «**LSB**» (see table at page 47).

Observación: **En la configuración U**: Para seleccionar la banda de frecuencia **ENG**, ponga el conmutador de modo (5) en la posición «**FM**». Para seleccionar la banda de frecuencia **CEPT**, ponga el conmutador de modo (5) en la posición «**AM**» o «**USB**» o «**LSB**» (véase cuadro página 47).

Anmerkung: **In der Konfiguration U**: Um das Frequenzband **ENG** auszuwählen, bringen Sie den Moduswahlschalter (5) in die Stellung «**FM**». Um das Frequenzband **CEPT** auszuwählen, bringen Sie den Moduswahlschalter (5) in die Stellung «**AM**» oder «**USB**» oder «**LSB**» (siehe Tabelle auf Seite 47).

La bande de fréquence et la puissance d'émission de votre appareil doivent correspondre à la configuration autorisée dans le pays où il est utilisé.

La banda de frecuencias y la potencia de emisión de su aparato deben corresponder a la configuración autorizada en el país donde él es utilizado.

The frequency band and the transmission power of your transceiver must correspond with the configuration authorized in the country where it is used.

Das Frequenzband und die Sendungsleistung Ihres Gerätes müssen übereinstimmen mit den Normen zugelassen im Land worin es benutzt ist.

Pays dans lesquels il existe des limitations particulières (Licence¹)

Countries in which there are particular restrictions

Países en los cuales existe algún tipo de limitación (Licencia¹ / Registro²)

Länder mit besonderen Beschränkungen (Lizenz¹ / Register²)

	AT	BE	BG	CH	CY	CZ	DE	DK	EE	ES	FI	FR	GB	GR	HU	IE	IS	IT	LT	LU	LV	MT	NL	NO	PL	PT	RO	SE	SI	SK
Licence ¹	⚠	⚠		⚠		⚠	⚠			⚠			⚠	⚠				⚠				⚠						⚠		
Register ¹																									⚠	⚠				
AM	⚠	⚠	⚠			⚠			⚠				⚠		⚠					⚠	⚠	⚠		⚠					⚠	⚠
BLU / SSB	⚠	⚠	⚠			⚠			⚠				⚠		⚠					⚠	⚠	⚠		⚠	⚠				⚠	⚠

Pays dans lequel la réglementation nationale autorise une puissance d'émission supérieure à la limite établie dans la norme harmonisée, précisée dans le quatrième paragraphe de la préface de la norme harmonisée EN 300 433.

Countries in which the national regulations authorize a transmission power superior to the limit fixed by the harmonised standard, notified in the 4th paragraph of the preface of the proper harmonised standard EN 300 433.

Países en los cuales la reglamentación nacional autoriza una potencia de emisión superior al límite establecido en la norma armonizada, advertido en el cuarto parrafo del preámbulo la propia norma armonizada EN 300 433.

Länder in denen die nationale Regelungen ein Sendeleistung zulassen die höher ist als die von der harmonierte Norm festgelegte Toleranz, angezeigt in 4. Paragraph der Vorrede der harmonierten Norm EN 300 433.

	IT	ES	PL
4W AM	✓	✓	✓
12W pep BLU	✓	✓	

Groupe
PRESIDENT
ELECTRONICS

SIEGE SOCIAL/HEAD OFFICE - FRANCE
Route de Sète - BP 100 - 34540 BALARUC
Site Internet : <http://www.president-electronics.com>
E-mail : groupe@president-electronics.com



CE 0341 ! UTZZ01560ZZ(0)

0862/09-07

PRESIDENT